

MATERIAL OF CONSTRUCTION

NO.	PART	MATERIAL		
		ANSI	ANSI	ANSI
1	Body	A351-CF8M	A351-CF8	A216-WCB
2	End Cap	A351-CF8M	A351-CF8	A216-WCB
3	Ball	A351-CF8M	A351-CF8	
4	Ball Seat	TFM1600 / PTFE / RTFE		
5	Bolting	A193-B8		A193-B7
6	Stem	316	304	
7	Anti-Stastic	316	304	
8	Thrust Washer	PTFE		
9	Stem Packing	PTFE / GRAFOIL*		
10	Bushing	50%SS+50%PTFE / 304*		
11	Gland	316		
12	Belleville Washer	301		
13	Stem Nut	A194-8		
14	Stop-Lock-Cap	304		
15	Handle Nut (1/2" ~ 2-1/2")	A194-8		
16	Lever (1/2" ~ 2-1/2")	304		
17	Handle Sleeve	VINYL PLASTIC		
18	Lock Device (1/2" ~ 2-1/2")	304		
19	Body Gasket	PTFE / 316 SPIRAL WOUND+GRAFOIL*		
20	Bolt Nut	A194-8	A194-2H	
21	Pipe Handle (3" ~ 8")	A53+Zn PLATED		
22	Handle Adapter (3" ~ 8")	A351-CF8		
23	Set Screwed (3" ~ 8")	A2-70		
24	O-Ring	FKM (VITON)		
25	Bolting (3" ~ 8")	A2-70		
26	Stop Bolt	A2-70		
27	Nameplate	304		
28	Worm Gear	Package		
29	Support Washer	304		
30	Stop Nut	A2-70		

*Materials for KV-L60 (Fire Safe Type)

JIS 10K/20K 2-PC Body, Flanged Ends, Full Port

KV-L4A, KV-L4C (Direct Mount Type)
KV-L6A, KV-L6C (Direct Mount Type / Fire Safe Type)

DESIGN FEATURES:

- Built-in ISO 5211 Direct Mounting Pad Easy Automation
- **Fire Safe** Design Approved
- Anti-Static Devices for Ball-Stem-Body
- Blow-out Proof Stem
- Pressure Balance Hole in Ball Slot
- **TA-LUFT** Design Approved
- Casting Boss on Body for Draining
- Options : 1. Actuator 2. Limit Switch 3. Positioner

APPLICABLE STANDARDS:

- Design : ASME B16.34
- Fire Safe : API 607 5th 2005, ISO 10497
- Face to Face : JIS B2002 (ASME B16.10)
- Flanged Ends: JIS B2220
- Wall Thickness : ASME B16.34
- Inspection & Testing : API 598, API 6D

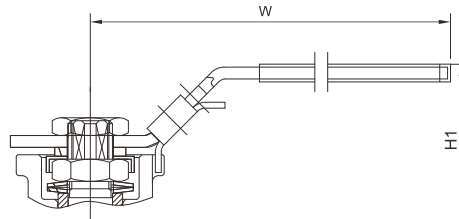
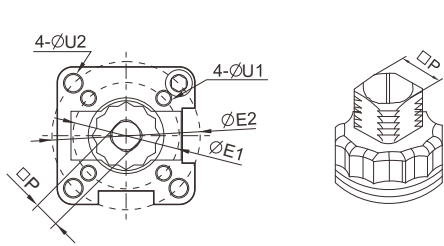

SIZE: 15A ~ 65A

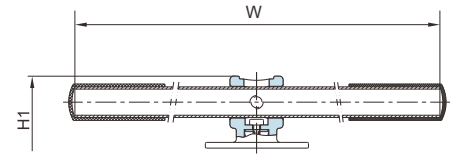

SIZE: 80A ~ 200A

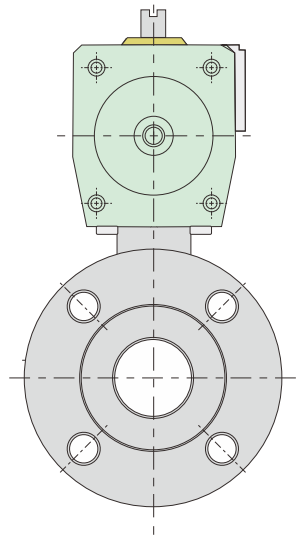
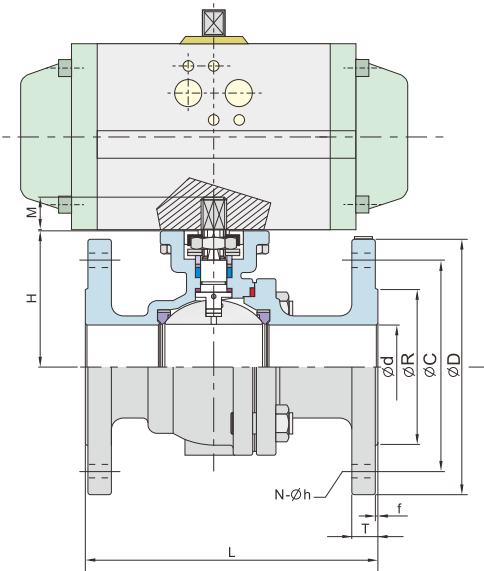

■ JIS 10K

KV-L4A, KV-L6A

Unit: mm

SIZE	d	L	R	D	C	T	f	N	h	H	H1	W	M	P	U1	U2	E1	E2	ISO 5211	
15A	1/2"	15.0	108	51	95	70	12	1	4	15	48	78	145.0	9	9	6	6	36	42	F03-F04
20A	3/4"	20.0	117	56	100	75	14	1	4	15	53	84	145.0	9	9	6	7	36	50	F03-F05
25A	1"	25.0	127	67	125	90	14	1	4	19	64	96	175.0	11	11	6	7	42	50	F04-F05
32A	1-1/4"	32.0	140	76	135	100	16	2	4	19	70	101	175.0	11	11	6	9	42	70	F04-F07
40A	1-1/2"	38.0	165	81	140	105	16	2	4	19	71	105	190.0	14	14	7	9	50	70	F05-F07
50A	2"	50.0	178	96	155	120	16	2	4	19	80	113	190.0	14	14	7	9	50	70	F05-F07
65A	2-1/2"	63.5	190	116	175	140	18	2	4	19	102	150	265.0	17	17	9	11	70	102	F07-F10
80A	3"	76.0	203	126	185	150	18	2	8	19	112	176	300.0	17	17	9	11	70	102	F07-F10
100A	4"	100.0	229	151	210	175	18	2	8	19	140	211	400.0	22	22	N/A	11	N/A	102	F10
125A	5"	125.0	356	182	250	210	20	2	8	23	183	263	600.0	27	27	14	N/A	125	N/A	F12
150A	6"	150.0	394	212	280	240	22	2	8	23	204	284	800.0	27	27	14	N/A	125	N/A	F12
200A	8"	200.0	457	262	330	290	22	2	12	23	253	334	800.0	27	27	14	N/A	125	N/A	F12

■ JIS 20K

KV-L4C, KV-L6C

Unit: mm

SIZE	d	L	R	D	C	T	f	N	h	H	H1	W	M	P	U1	U2	E1	E2	ISO 5211	
125A	5"	125.0	381	195	270	225	26	2	8	25	183	263	600.0	27	27	14	N/A	125	N/A	F12
150A	6"	150.0	403	230	305	260	28	2	12	25	204	284	800.0	27	27	14	N/A	125	N/A	F12
200A	8"	200.0	502	275	350	305	30	2	12	25	253	334	800.0	27	27	14	N/A	125	N/A	F12